

Agilent 85071D

Materials Measurement Software

Product Overview



Features of 85071D

- Runs on a PC, or internally on the PNA series of network analyzers, eliminating the need for both a PC and a GPIB card.
- Measure permittivity and permeability over a broad frequency range (network analyzer dependent).
- View measurement results in a variety of formats (ϵ_r' , ϵ_r'' , $\tan \delta$, μ_r' , μ_r'' , $\tan \mu_m$ or Cole-Cole)
- Coaxial air lines or rectangular waveguide transmission lines can be used as sample holders
- Compatible with free space measurements
- Five measurement models
- Component object model (COM) interface allows the measurement to be setup, triggered, and read from a user-written program. Example Visual Basic and Visual C++ projects are included to aid program development.



Agilent Technologies

Measure ϵ_r^* and μ_r^* over a wide frequency range

The Agilent Technologies 85071D materials measurement software determines the intrinsic electromagnetic properties of many dielectric and magnetic materials. The complete system is based on a versatile network analyzer which measures the material's response to RF or microwave energy.

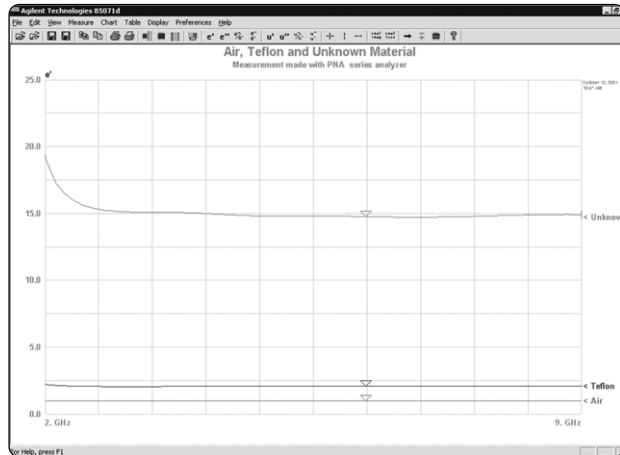

Examine the properties of materials across the RF and microwave frequency spectrum.

Small samples of the material under test (MUT) are machined to fill the cross section of coaxial or waveguide transmission lines and measured within the fixture. Or large, flat samples are placed between antennas and measured under free space conditions.

The 85071D software controls the network analyzer and calculates the complex permittivity ϵ_r^* (or dielectric constant) and permeability μ_r^* , including the loss factor or loss tangent. Results are displayed as a function of frequency, with 1 to 2% accuracy (typical). Depending on the Agilent network analyzer and fixture used, frequencies can extend to 110 GHz.

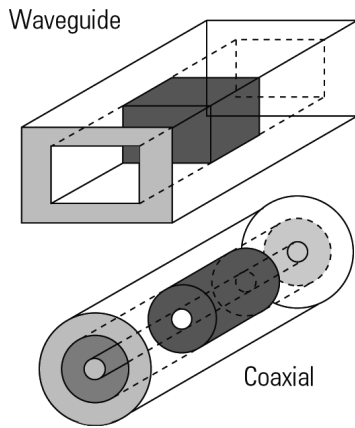

Transmission line method

Coaxial airlines or rectangular waveguide transmission lines can be used as sample holders. Solid samples that can be precisely machined to fit inside the fixture give the best results.

The 85071D features an algorithm that corrects for the effects of air gap between the sample and fixture, which can be the largest source of error with a transmission line technique.

Simple coaxial or waveguide transmission lines hold the samples of material under test.

Measurement attributes

- Nicolson-Ross model provides sample position invariance
- One-port arbitrary backed model measures thin samples accurately
- Air gap correction improves the accuracy of transmission line methods
- Compatibility with free space measurements

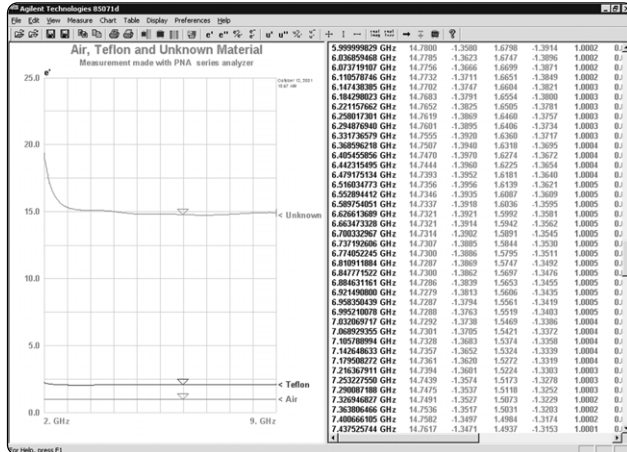

Split screen window and marker aids in data analysis. Simply click on a point on the chart or list to activate the marker.

Free space method

Large, flat samples of materials can be placed between antennas to measure their properties in a non-contacting fashion. Because the sample is not contained in a fixture, the error from air gap is not a concern. Free space is best when measuring materials that must be heated to very high temperatures or when measuring a large area of a material which is non-uniform (i.e., honeycomb, composite). A TRL or TRM (Thru-Reflect-Line or Match) calibration is ideal under free space conditions with a full S-parameter test set configuration. Time domain gating can also be used to remove mismatch effects.

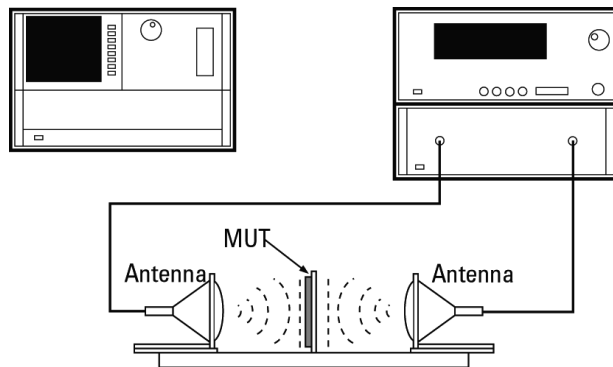

Antennas direct beams of microwave energy at or through a material, without enclosing it in a fixture.

Wide range of models

The 85071D has five different algorithms to choose from, each with specific benefits:

The traditional method has been described by Nicolson and Ross. It is best for magnetic materials such as ferrites and absorbers. It calculates both ϵ_r^* and μ_r^* , including loss, from a two-port measurement of a single sample. You get results quickly and easily.

The 85071D also includes two other two-port algorithms for non-magnetic materials ($\mu_r^*=1$). These models do not suffer from discontinuities at frequencies where the sample length is a multiple of half-wavelengths. These models are used to measure long, low-loss materials with greater accuracy.

While the two-port algorithms are best for most solid materials, one-port algorithms provide a simple calibration and measurement and are better suited to measurements of liquids and powders. A shorted waveguide can be turned on end and filled with a material. One-port fixtures are also better suited for high-temperature measurements where one end of the fixture can be heated, while cooling mechanisms at the other end protect the network analyzer.

Although one-port fixtures are usually terminated with a short circuit, the 85071D also accommodates an arbitrary termination which produces more reliable results for thin samples.

Performance characteristics

Specifications describe the warranted performance over the temperature range 0 to 55 °C. Supplemental characteristics are intended to provide information useful in applying the instrument, by giving typical but non-warranted performance parameters. These are denoted as “typical,” “nominal,” or “approximate.”

Frequency range (typical)

100 MHz to 110 GHz depending on network analyzer, fixture and material.¹

Accuracy (typical)

1 to 2 percent

Transmission line fixtures

Coaxial fixtures (beadless airlines) are broadband but require a sample shaped into a flat-faced torus.

Waveguide fixtures are band-limited but operate at higher frequencies and accept a simpler rectangular shape.

Samples must completely fill the cross section of the transmission line without gaps at the fixture walls. Faces at either end must be flat, smooth and perpendicular to the long axis.

Free space systems

Large, flat, thin, parallel-faced samples are placed between antennas and measured under free space conditions. Antennas should maintain a planar “far-field” wavefront to the sample.²

Material under test assumptions

Material is homogeneous (uniform composition) with no layers.³ Non-isotropic (uniform orientation) materials can be measured in waveguide.

Software menu items

File

Save or recall measurement setups or previous measurement results. Print copies of the measurement results in a tabular or graphical format.

Edit

Copy the measurement results to the clipboard. Either graph or the tabular listing can be copied. This allows your measurements results to be pasted into other applications.

View

Select what you want to view. Selections include the toolbar, status bar, table of the measurement data and chart of the measurement data.

Measure

Trigger a measurement; recalculate without remeasuring the MUT; set measurement model, define sample holder and set measurement attributes.

Chart

Select the format to be displayed on the chart. Choices include ϵ_r , ϵ_r'' , $\tan \delta$, u_r' , u_r'' , $\tan \delta_n$ and Cole-Cole. Set scale factors or “autoscale.” Select from linear, semi-log, or log-log representations.

Table

Choose between a tabular formatting of real and imaginary or real and $\tan \delta$.

Display

Display current measurement data; save/display up to 3 memory traces; compare data to reference trace with trace math. Turn the marker on or off.

Preferences

Select your preferences of fonts, colors, and annotations used to plot and list the measurement data.

Help

On line help including the product manual.

ToolBar

Provides single click access to the most important menu items.

1. Minimum frequency is set by the maximum practical sample length (L): $f \text{ (in GHz)} > \frac{1}{\sqrt{\epsilon_r \mu_r}} \frac{30 \text{ cm}}{L \text{ (in cm)}} \frac{20}{360}$

2. Antenna should be placed $\approx 2d/\lambda$ from the sample, where d is the larger of the antenna or sample diameter.

3. If the material is not homogeneous through the length of the sample (i.e., layers), the reflection from the front (S_{11}) and back (S_{22}) face will be different and will lead to a potentially erroneous result. If the material is not homogeneous across the face of the sample, the result is an average value over the cross section that is exposed to the EM field (weighted by the intensity).

Software models

Model name	Measured S-parameters	Number of samples	Optimum sample thickness ¹	Results	Comments
Refl/Tran μ & ϵ (Nicolson-Ross)	$S_{11}, S_{21}, S_{12}, S_{22}$ (or S_{11}, S_{21})	1	$\lambda_g/4$	ϵ_r^* & μ_r^*	Fast, but has $n\lambda/2$ discontinuities. Best for magnetic, short or lossy MUTs
Refl/Tran ϵ (NIST Precision)	$S_{11}, S_{21}, S_{12}, S_{22}$	1	$n\lambda_g/2$	ϵ_r^*	Accurate, no discontinuities. Best for long, low-loss MUTs
Refl/Tran ϵ (Fast)	$S_{11}, S_{21}, S_{12}, S_{22}$ (or S_{11}, S_{21})	1	$n\lambda_g/2$	ϵ_r^*	Similar to precision but faster and better for lossy MUTs Best for long, low-loss MUTs
Refl ϵ (Short-backed)	S_{11}	1	$\lambda_g/2$	ϵ_r^*	Best for liquids or powders
Refl ϵ (Arbitrary-backed)	S_{11}	1	$\lambda_g/2$	ϵ_r^*	Best for thin films
Refl μ_r & ϵ_r (Single/Double)	S_{11}	1 ²	$\lambda_g/4$ ³	ϵ_r^* and μ_r^*	Best for liquids or powders

1. Where: $1g = \frac{1}{\sqrt{\frac{\epsilon_r \mu_r}{\lambda_0} - \frac{1}{\lambda_c}}}$ λ_c = cutoff frequency (omit for coaxial) and λ_0 = frequency (in GHz)

2. This model requires two measurements of one sample in different positions backed by a short, or two samples backed by a short, each measured once.
3. $\lambda_g/2$ for lower loss materials

Ordering information

85071D Material Measurement Software. Not included, but required to make a measurement is a PC* (see PC requirements), network analyzer and a sample holder (see pages 3 and 4).

Option 071 Upgrade from any older version of 85071 software.

Compatible network analyzers

PNA Series network analyzers:

2 port, 4 receivers	
E8356A	300 kHz to 3 GHz
E8357A	300 kHz to 6 GHz
E8358A	300 kHz to 9 GHz
E8364A	45 MHz to 50 GHz
2 port, 3 receivers	
E8801A	300 kHz to 3 GHz
E8802A	300 kHz to 6 GHz
E8803A	300 kHz to 6 GHz
3 port, 4 receivers	
N3381A	300 kHz to 3 GHz
N3382A	300 kHz to 6 GHz
N3383A	300 kHz to 9 GHz

Other network analyzers:

8752C	300 kHz to 6 GHz
8753D/E/ET/ES	30 kHz to 6 GHz
8719D/ET/ES	50 MHz to 13.5 GHz
8720D/ET/ES	50 MHz to 20 GHz
8722D/ET/ES	50 MHz to 40 GHz
8712C/ET/ES	300 kHz to 1.3 GHz
8714C/ET/ES	300 kHz to 3 GHz
8510C	45 MHz to 110 GHz

PC requirements *

- Windows® 95, 98, 2000, Me or Windows NT® 4.0
- GPIB interface card with a compatible driver (Agilent SICL or National Instruments 488.2M)
- CD drive

* Note: the 85071D can be installed and run on a PNA Series network analyzer, eliminating the need for both a PC and GPIB card. To install the 85071D on a PNA analyzer a PC with a CD drive is required to copy the 85071D installation files from the supplied CD to 3.5-inch disks.

Transmission line fixtures and accessories

Waveguide airlines

11644A series waveguide calibration kits contain a 1/4 wavelength line and a straight section which can also be used as sample holders. Contact Agilent Technologies for information on third party suppliers of other waveguide transmission lines.

Coaxial airlines

Agilent 8505X series coaxial verification kits contain airlines that can also be used as sample holders. Contact Agilent for information on third party suppliers of other coaxial transmission lines.

Accessories

Test port cables to connect fixture to network analyzer; adapters (as needed) to adapt cables to fixture; calibration kit to match connectors on fixture.

Free space antennas and accessories

Antennas

Contact Agilent for information on third party suppliers of free space antennas.

Accessories

Cables to connect antennas to network analyzer; adapters (as needed) to adapt cables to antennas; free space calibration standards.

Free trial demo

Evaluate a demo version of 85071D Materials Measurement Software for up to four weeks. Visit Agilent Technologies website at www.agilent.com/find/materials to download this demo program to your PC.

**Agilent Technologies'
Test and Measurement Support,
Services, and Assistance**

Agilent Technologies aims to maximize the value you receive, while minimizing your risk and problems. We strive to ensure that you get the test and measurement capabilities you paid for and obtain the support you need. Our extensive support resources and services can help you choose the right Agilent products for your applications and apply them successfully. Every instrument and system we sell has a global warranty. Support is available for at least five years beyond the production life of the product. Two concepts underlie Agilent's overall support policy: "Our Promise" and "Your Advantage."

Our Promise

Our Promise means your Agilent test and measurement equipment will meet its advertised performance and functionality. When you are choosing new equipment, we will help you with product information, including realistic performance specifications and practical recommendations from experienced test engineers. When you use Agilent equipment, we can verify that it works properly, help with product operation, and provide basic measurement assistance for the use of specified capabilities, at no extra cost upon request. Many self-help tools are available.

Your Advantage

Your Advantage means that Agilent offers a wide range of additional expert test and measurement services, which you can purchase according to your unique technical and business needs. Solve problems efficiently and gain a competitive edge by contracting with us for calibration, extra-cost upgrades, out-of-warranty repairs, and on-site education and training, as well as design, system integration, project management, and other professional engineering services. Experienced Agilent engineers and technicians worldwide can help you maximize your productivity, optimize the return on investment of your Agilent instruments and systems, and obtain dependable measurement accuracy for the life of those products.

**By internet, phone, or fax, get assistance with
all your test & measurement needs**

Online assistance:
www.agilent.com/find/assist

**Phone or Fax
United States:**
(tel) 1 800 452 4844

Canada:
(tel) 1 877 894 4414
(fax) (905) 282-6495

China:
(tel) 800-810-0189
(fax) 1-0800-650-0121

Europe:
(tel) (31 20) 547 2323
(fax) (31 20) 547 2390

Japan:
(tel) (81) 426 56 7832
(fax) (81) 426 56 7840

Korea:
(tel) (82-2) 2004-5004
(fax) (82-2) 2004-5115

Latin America:
(tel) (305) 269 7500
(fax) (305) 269 7599

Taiwan:
(tel) 080-004-7866
(fax) (886-2) 2545-6723

Other Asia Pacific Countries:
(tel) (65) 375-8100
(fax) (65) 836-0252
Email: tm_asia@agilent.com

**Product specifications and descriptions in this
document subject to change without notice.**

**© Agilent Technologies, Inc. 2001
Printed in USA October 23, 2001
5968-5331E**

